



MADE IN ITALY

SOLLEVATORI IDRAULICI PER FOSSA E SOTTOPONTE

HYDRAULIC TRANSMISSION JACKS
VERINS DE FOSSE HYDRAULIQUES
HYDRAULISCHE GETRIEBEBEHEBER

12

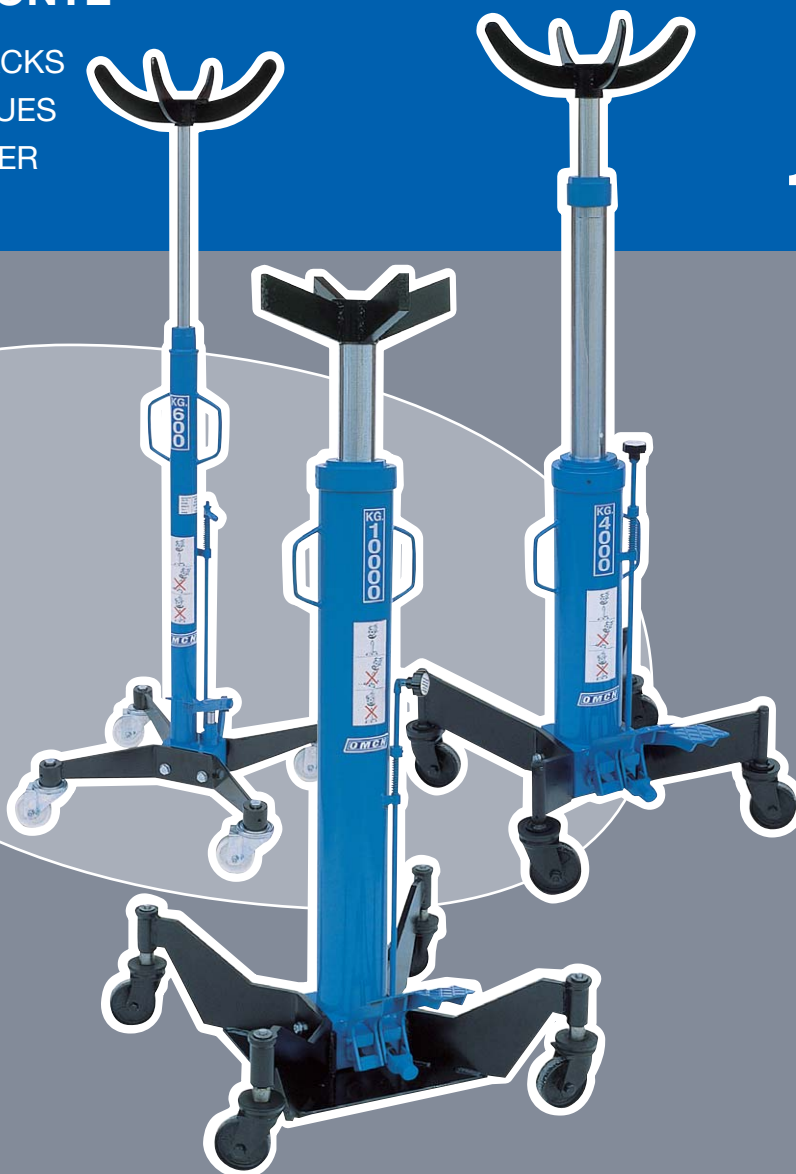

Art. SIF 1/73 - 0,25 Ton.
Art. SIF 1/A/73 - 0,4 Ton.
Art. SIF 2/A/73 - 0,6 Ton.
Art. SIF 2/73 - 1 Ton.
Art. SIF 3/73 - 1,5 Ton.
Art. SIF 4/73 - 2,5 Ton.
Art. SIF 5/73 - 6 Ton.
Art. SIF 6/73 - 10 Ton.

con stelo cromato
chromium plated rod
tige chromée
verchromter kolben



Art. SIF 1/73



Art. SIF 2/A/73



Art. SIF 3/73



Art. SIF 6/73

Art.		SIF 1/73	SIF 1/A/73	SIF 2/A/73	SIF 2/73	SIF 3/73	SIF 4/73	SIF 5/73	SIF 6/73
Portata Load capacity Portée Tragkraft:	Ton.	0,25	0,4	0,6	1	1,5	2,5	6	10
Altezza minima Minimum height Hauteur minimum Mindesthöhe:	mm.	1240	1240	1180	1190	1220	1350	1305	1315
Corsa 1° stelo First rod stroke Course première tige Hub 1. Stufe:	mm.	850	850	780	800	800	870	900	900
Larghezza base Base width Largeur de la base Basisbreite:	mm.	410	410	520	530	540	550	720	720
Lunghezza base Base length Longueur de la base Basislänge:	mm.	585	585	520	530	540	550	720	720
Ø stelo Ø rod Ø tige Ø Hub:	mm.	22	24	30	35	45	50	60	60

Art. SIF 4/73 - SIF 5/73 - SIF 6/73:
Forniti con doppio gruppo pompante.
Supplied with double pumping group.

Fournis avec double groupe pompant.
Mit 2 Hubgeschwindigkeiten.

Art. SIF 5/73 - SIF 6/73:

Vengono forniti con ruote rientranti con carico
≥ 300 Kg.

Livrés avec roues escamotables avec poids ≥
300 Kg.

They are supplied with retractile wheels with
charge ≥ 300 Kg.

Mit einfedernden Rädern mit Last ≥ 300 Kg.

Art. SIF 7/73 - 0,8 Ton.
Art. SIF 8/73 - 1,5 Ton.
Art. SIF 10/73 - 4 Ton.

a due stadi
 con steli cromati
 at two stages
 chromium plated rods
 a deux etages
 avec tiges chromées
 mit verchromten
 teleskopkolben



Art. SIF 7/73



Art. SIF 10/73

Art.		SIF 7/73	SIF 8/73	SIF 10/73
Portata Load capacity Portée Tragkraft:	Ton.	0,8	1,5	4
Altezza minima Minimum height Hauteur minimum Mindesthöhe:	mm.	890	960	930
Corsa 1° stelo First rod stroke Course première tige Hub 1. Stufe:	mm.	470	470	460
Corsa 2° stelo Second rod stroke Course seconde tige Hub 2. Stufe:	mm.	520	530	510
Larghezza base Base width Largeur de la base Basisbreite:	mm.	530	550	550
Lunghezza base Base length Longueur de la base Basislänge:	mm.	530	550	550
Ø stelo Ø rod Ø tige Ø Hub:	mm.	30	35	45

Art. SIF 8/73 - SIF 10/73:

Forniti con doppio gruppo pompante.
 Supplied with double pumping group.

Fournis avec double groupe pompant.
 Mit 2 Hubgeschwindigkeiten.

Art. SIF 5/73 IP - 6 Ton.
Art. SIF 6/73 IP - 10 Ton.

con stelo cromato
funzionamento oleopneumatico
chromium plated rod
air-hydraulic functioning
tige chromée
fonctionnement hydropneumatique
verchromter kolben
pneumatisch-hydraulischer Betrieb



Art. SIF 6/73 IP

Art.		SIF 5/73 IP	SIF 6/73 IP
Portata - Load capacity Portée - Tragkraft:	Ton.	6	10
Altezza minima - Minimum height Hauteur minimum - Mindesthöhe:	mm.	1305	1315
Corsa 1° stelo - First rod stroke Course première tige - Hub 1. Stufe:	mm.	900	900
Larghezza base - Base width Largeur de la base - Basisbreite:	mm.	720	720
Lunghezza base - Base length Longueur de la base - Basislänge:	mm.	720	720
Ø stelo - Ø rod Ø tige - Ø Hub:	mm.	60	60
Pressione di utilizzo - Feeding pressure Pression d'alimentation - Benötigter Luftdruck:	BAR	8/10	8/10

Vengono forniti con ruote rientranti con carico
≥ 300 Kg.

They are supplied with retractile wheels with
charge ≥ 300 Kg.

Livrés avec roues escamotables avec poids
≥ 300 Kg.

Mit einfedernden Rädern mit Last ≥ 300 Kg.

Art. SIF/XR - 0,1 Ton.

**SOLLEVATORE IDRAULICO SOTTOPONTE
PER SMONTAGGIO PNEUMATICI**

Articolo ideale per lo smontaggio e il rimontaggio ruote per autovetture, veicoli commerciali e SUV, posti su ponti sollevatori a 2 colonne o doppia forbice. Comando a pedale, rulli registrabili in larghezza ed eccentrici per permettere il rapido posizionamento dei bulloni ruota.

**HYDRAULIC TRANSMISSION JACK
FOR TYRE DISASSEMBLING**

Right article to disassemble and install wheels of cars, commercial vehicles and SUV placed on 2 post autolifts or twin-scissor hoists. Foot control, rollers recordable in width and outlying, which allows to place wheel-nuts quickly.

**VERIN DE FOSSE
A DEMONTER LES PNEUS**

Idéal pour le démontage et remontage des roues de voitures, véhicules commerciaux et tous-terrains placés sur pont élévateur à 2 colonnes ou double ciseaux. Commande à pédale, rouleaux excentrés et réglables en largeur pour permettre de positionner rapidement les boulons des roues.

HYDRAULISCHER GETRIEBEBEHER

Gerät zum Demontieren und installieren von Reifen von PKW, Lieferwagen und SUV platziert auf 2 Säulen-Bühnen oder Doppel-Scheren-Hebebühnen. Fußbedienung, Rollen-Einstellung in Breit und Seitwärts, welche das schnelle montieren von Radmutter ermöglicht.

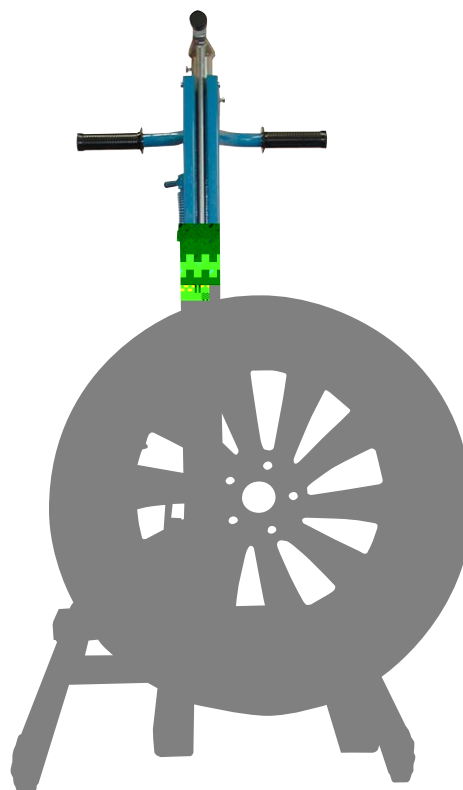

Art.	SIF/XR
Portata - Capacity - Portée - Tragkraft:	0,1 Ton.
Ingombro massimo basamento - Maximum base volume - Encombrement maximum de la base - Max. Grundvolumen:	600 x 640 mm.
Altezza minima da terra - Minimum height from the floor - Hauteur de terre minimum - Min. Höhe vom Boden:	90 mm.
Altezza massima di sollevamento - Maximum lifting height - Hauteur de levage maximum - Max. Hubhöhe:	950 mm.
ø Max. cerchio utilizzabile - Max. ø useful rim - ø Max. compatible des jantes - Max. verwendbarer Felgendurchmesser:	22"
Larghezza Max. battistrada pneumatico - Max. width tread wheel - Largeur Max. de la bande pneumatique - Max. Laufkranzbreite:	305 mm.

